

Catalog Number:

Notes:

Type of Fan:

FEATURES & SPECIFICATIONS

Z-Chill™ Fan & Diffuser System Intended Use: Breakthrough, patent-pending system designed to effectively spot cool the unconditioned space within a facility by distributing tempered air and provide companies an economical tempered cooling solution to keep business operating at their highest level. Applications include, transportation maintenance, aviation hangars, agriculture, education, commercial and retail spaces, government, manufacturing, recreational, warehousing and other indoor spaces where comfort and energy are required with minimum 20' ceiling

NUMBER & TYPE OF BLADES: (5) patent-pending Z-Tech™ blades with 20° plus pitch.

BLADE CONSTRUCTION: Two-piece extruded anodized aluminum blade with ABS leading edge and end caps with UV inhibitors. Frame is powder coated steel with a cast aluminum hub A356-T6. Leading edge blade is riveted to the primary blade with stainless steel rivets.

DIFFUSER CONSTRUCTION: Constructed of cold rolled steel and protected with powder coated paint and feature a closed cell thermal insulation design to prevent/minimize condensation on the outside of the entire unit. with bottom perforations to equally distribute tempered air over the blades.

ELECTRICAL (MOTOR): NORD™ motor utilizes cast iron housing with a precise shaft and gear alignment that has a high load bearing capacity. Single housing block in which all bearing points are integrated. No sealing faces are subjected to torque or lateral forces. IP 55; UL 1004; 120/230/460/575v; single and three phase available.

ELECTRICAL (CONTROLLER): Premium control with hardware flexibility, programmability, and scalability for an optimal solution. ABB™ Variable Frequency Drive – Nema 4X, IP66/67. ESFR relay ready to connect to existing fire suppression systems, integral lock out, tag out (LOTO) disconnect ship standard. ROHS compliant.

INSTALLATION: Suitable for mounting by I-Beam, Top Chord angle iron, Bottom Chord angle iron, L-Bracket, Z-Purlin and Wood Beam. Standard mount is used for 6"-10" I-beams, XL mount is used for 12"-15" I-beams. 2 foot down tube is standard with Z-Chill system.

SAFETY: Safety ring (1/4" powder coated steel), two safety cables (5/16" stainless steel aircraft cable), guy wires (1/8" stainless steel aircraft cable) – with 4 foot or greater down tube extension.

DESIGNER COLOR: Optional color combinations & designs available.

OPERATING TEMPERATURES: Motor & Gearbox (20°F to 122°F); Controller (20°F to 122°F).

WARRANTY: Lifetime warranty on blades, hub and mounting system. 15-year warranty on motor, gearbox and controller.

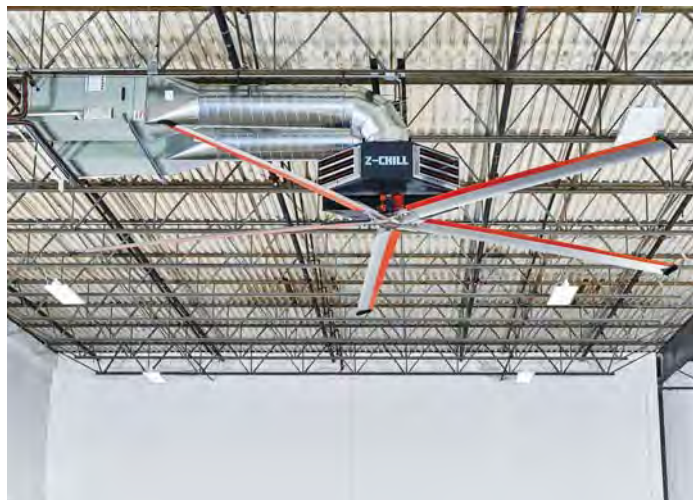
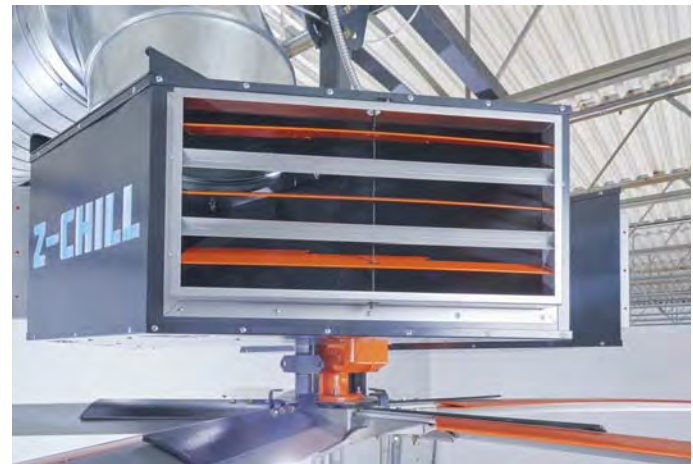

ORDERING INFORMATION

Example: GFY - Z-CHILL - 5 - 24 - NMSTD - 460 - 3 - 2 - STD - T - ABBSTD

Family	Style	Blades	Diameter	Motor	Voltage	Phase	Down Tube	Mount	Mounting Kit	Controller	Options
GFY	Z-Chill	5	16 18 20 22 24	NMSTD	120 ¹ 230 ¹ 460 ¹ 575 ¹	1 (Single) 3 (Three)	2 (2FT) ² 3 (3FT) ³	STD ⁵ XL ⁶	T ⁷ CB ¹⁴ WB ¹⁴	ABBSTD	DS ^{8,9} RK ¹⁰ CP ¹¹ FM ¹²

FOOTNOTES

- 1) Available voltages: 3 Phase Applications: 200-240VAC | 380-480VAC|500-600VAC ; Single Phase Applications: 100-120VAC (16 FT)|200-240VAC (20, 24 FT)
- 2) 2 FT down tube is minimum required with the Z-Chill™ Fan & Diffuser System.
- 3) 3 FT down tube is available as an option. Longer down tubes are not available with Z-Chill equipped fans.
- 4) Consult the factory for down tubes longer than 4 FT. Approval required.
- 5) Use STD mount (6-10" beams) for optional Truss Mount, Z-Purlin Mount and Concrete Beam Mounts.
- 6) XL Mount is only used for 12"-15" I-beam
- 7) Truss Mount require contractor supplied 3"x3"x1/4" steel angles cut to size. See **Z-Tech™ Installation and Technical Operations Guide**.
- 8) Designer Series Options (refer to pages 12 & 13):
 - Option #1 - Motor and all (5) Z-Tech™ leading edges a standard RAL color. Customer logo to replace Go Fan Yourself® logo on hub.
 - Option #2 - Motor and (3) Z-Tech™ leading edges one standard RAL color, (2) Z-Tech™ leading edges another standard RAL color. Customer logo to replace Go Fan Yourself® hub logo.
 - Option #3 - Motor and all (5) Z-Tech™ leading edges a standard RAL color. Aluminum Blades one standard RAL color. Customer logo to replace Go Fan Yourself® logo on hub.
 - Option #4 - Motor and (3) Z-Tech™ leading edges one standard RAL color, (2) Z-Tech™ leading edges another standard RAL color. Aluminum Blades one standard RAL color. Customer logo to replace Go Fan Yourself® hub logo.
 - Option #5 - Custom - Motor MUST be a standard RAL color. Z-Tech™ leading edges and aluminum blades may be a custom color. Customer logo to replace Go Fan Yourself® hub logo.
- 9) Designer Series fans have custom lead times. Consult the factory to receive a lead-time quote for your desired option.
- 10) Keypad mounts inside a Go Fan Yourself® custom mounting bracket. Kit ships complete with 35 FT CAT6 data cable. Max. cable length is 300 FT.
- 11) Longer CAT6 data cables to be supplied by installing contractor.
Consult the factory. ABB control's protocol compatibility adapts to the customers existing building management software. Not all programming options may be available on every control.
- 12) Optional fan mounted VFD. ABB VFD control ships mounted directly to the fan on an engineered bracket. VFD to fan connections made in the field. Contractor needs only to run power to the fan location and connect it to the controller. Remote Keypad Kit ships automatically with a 100' CAT6 data cable. Max. cable length is 300 FT.
- 13) Contact a local structural engineer for all concrete and wood beam applications to verify the structure will support the fan with the prescribed mounting system.

Fan Diameter	16FT	18FT	20FT	22FT	24FT
Fan Weight with Z-Chill	460 lbs.	505 lbs.	525 lbs.	535 lbs.	545 lbs.
Nominal Motor	1.5 HP (1.1kw)	2 HP (1.5kw)	2 HP (1.5kw)	2 HP (1.5kw)	2 HP (1.5kw)
Nominal RPM	70	53	53	53	53
Air Movement (CFM)	191,285	268,920	346,550	385,775	425,000
Max. Stratification Coverage	160 FT	180 FT	200 FT	220 FT	240 FT
Max. Cooling Diameter	130 FT	135 FT	150 FT	165 FT	180 FT
Torque	240 ft.-lbs.	377 ft.-lbs.	377 ft.-lbs.	377 ft.-lbs.	377 ft.-lbs.
Power Consumption	989 W	1449 W	1449 W	1449 W	1449 W
Single Phase Voltage Nominal Amperage	120v / 18.0	240v / 15.0	240v / 15.0	240v / 15.0	240v / 15.0
Nominal Amperage (230v)	4.3	6.3	6.3	6.3	6.3
Nominal Amperage (460v)	2.15	3.15	3.15	3.15	3.15
Nominal Amperage (575v)	1.72	2.52	2.52	2.52	2.52

NOTE:

If the installation is in a seismic zone, contact a local structural engineer to verify fan mount requirements.

Number & Type of Blades: 5 patent-pending Z-Tech™ blades with 20° plus pitch

Blade Construction: Extruded anodized aluminum blade with ABS leading edge and end caps with UV inhibitors

Diffuser Construction: Constructed of cold rolled steel and protected with powder coated paint and feature a closed cell thermal insulation designed to prevent/minimize condensation on the outside of the entire unit.

Standard or Optional XL Mount: Universal I-beam clamps; Down tubes from 1-10ft in length

ABB VFD Controller: NEMA 4X, IP 66/67. Premium motor control w/ hardware flexibility, programmability & scalability for an optional solution. ROHS compliant, ESFR relay ready, integral LOTO disconnect

Safety Features: Safety ring (1/4" powder coated steel), two safety cables (5/16" stainless steel aircraft cable), guy wires (1/8" stainless steel aircraft cable) - with 4' or greater down tube extension

Warranty: 15-year: motor, gearbox, and control panel
Lifetime: blades, hub, and mounting system

Refer to **Installation & Technical Operations Guide** for warranty specifications/exclusion

COMPONENT DESCRIPTIONS NOMINAL DIMENSIONS MOUNTING/MOTOR DETAIL

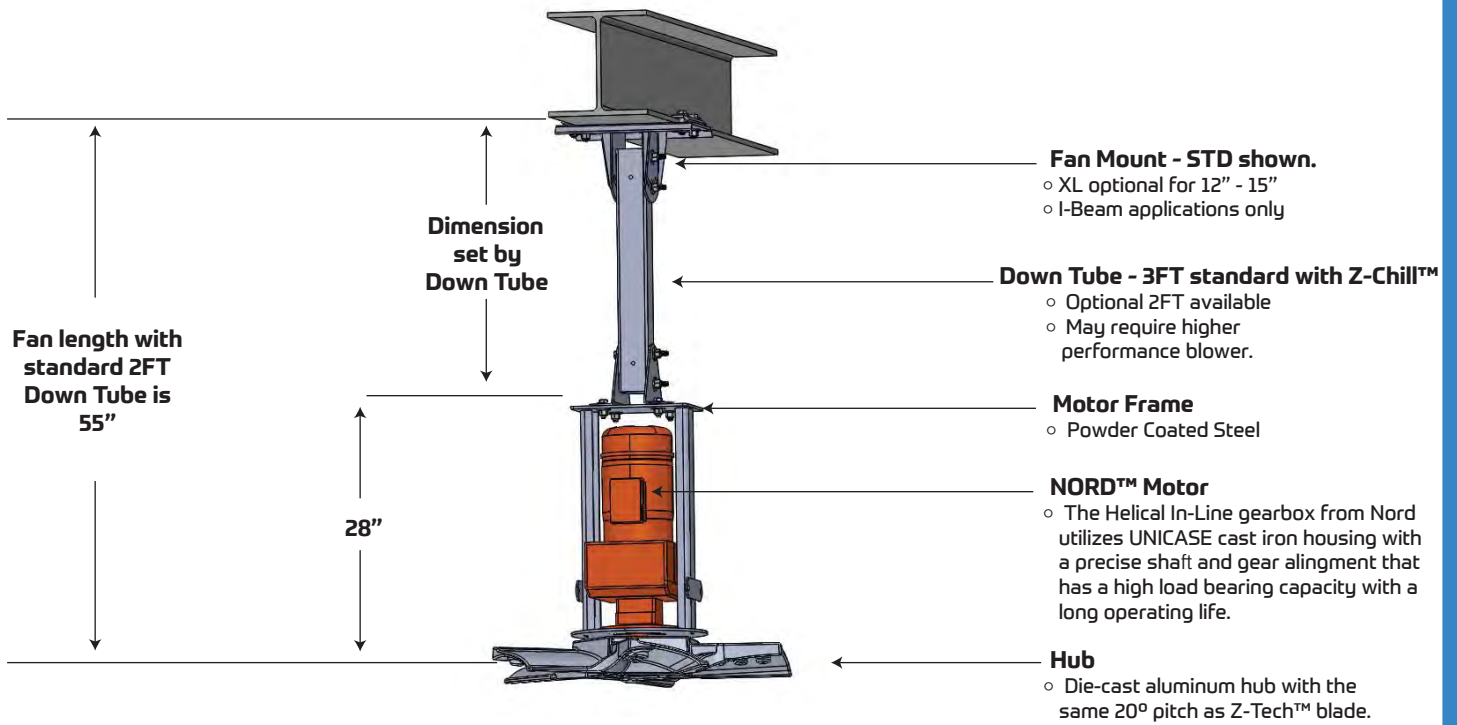

Z-CHILL™ DIFFUSER PATENT-PENDING

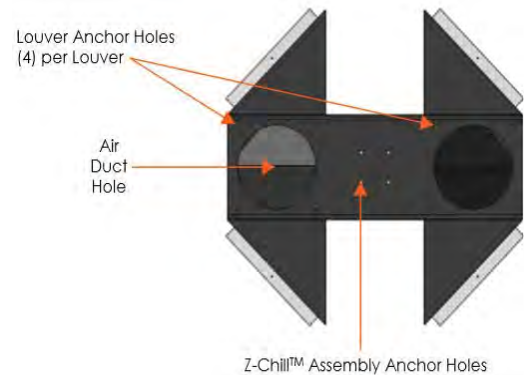
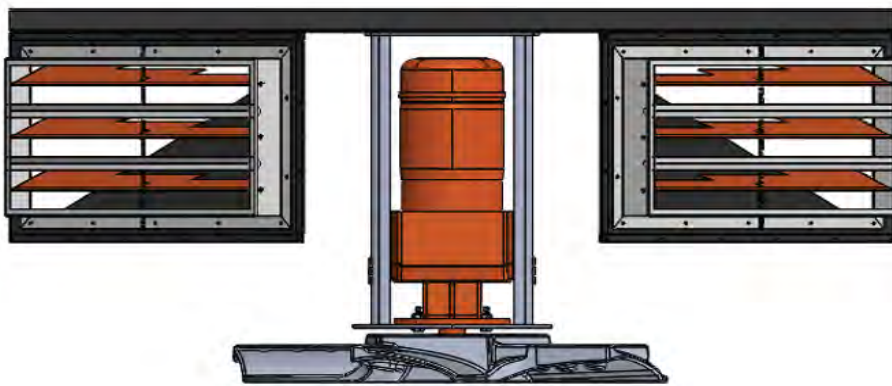

- Dual Z-Chill™ diffusers are specifically designed to equally distribute both filtered, conditioned and or forced heat into the designed air distribution pattern of the Z-Tech™ (16, 20, & 24ft) fans. Includes a closed cell thermal insulation design to prevent/minimize condensation on the outside of the entire unit.
- Z-Chill™ diffusers incorporate stepped Z-Tech™ internal prisms to equally split the incoming conditioned air and the adjustable stepped Z-Tech™ vented louvers are designed to equally distribute the air across the entire circumference of the 5-blade Z-Tech™ stepped fan blade design. The diffusers include bottom perforations that are designed to disperse air spread in the center.
- The system is direct mounted between the down tube and weldment and motor/hub mounting yoke hardware and requires no additional support. The incoming spiral insulated ducting (provided by others) will need support prior to final connections. Dual Z-Tech™ diffusers feature 16-inch round HVAC ducting receptacles. Receptacles are rated for 5-10 ton HVAC capacity each (supplied by others). It is recommended all attached spiral inlet ducting be wrapped and insulated.
- Z-Chill™ works the same with tempered forced air (HVAC systems) for both cooling and heating. Roof top (industrial & commercial) units as well as split systems incorporate energy efficient heat pumps that can disperse the heat through the Z-Chill™ dual diffusers.
- True reversibility is achieved because of the symmetrical Z-Tech™ blades including the engineered pitch, rake and cup. Applying forced heat and stratifying several thousand square feet without creating uncomfortable wind chills make this superior patent-pending technology the only chameleon to properly solve conditioned air movement in large spaces at a low operating cost.

FLEXIBLE CLOSED CELL SHEET INSULATION

- INSUL-SHEET® insulation is an environmentally friendly, CFC-free, flexible elastomeric thermal insulation.
- Non-porous, non-fibrous and resists mold growth. An EPA registered antimicrobial agent is incorporated into the product providing additional protection against mold, fungal and bacterial growth.
- Retards heat gain and prevent condensation or frost formation on cold equipment, tanks, vessels, ducts, or large O.D. pipes.
- Tough skin which withstands tearing, rough handling, and severe environmental conditions, and yet is quite flexible for easy installation and has superior cold weather flexibility.
- K-Flex USA elastomeric insulation products are GREENGUARD® certified as low VOC materials, meeting the requirements of the “Children and Schools” classification, the most stringent requirements. Additionally, all K-Flex USA elastomeric insulation products are GREENGUARD® listed for mold resistance and meet the “mold resistant” criteria.
- INSUL-SHEET® thickness has been calculated to control condensation on cold surfaces.
- The closed-cell structure and unique formulation of INSUL-SHEET® effectively retards the flow of moisture vapor, and is considered a low transmittance vapor retarder.
- INSUL-SHEET® insulation in thicknesses of 1 1/2" (38 mm) and below has a flame spread rating of 25 or less and a smoke development rating of 50 or less as tested by ASTM E 84 Method of Testing entitled: “Surface Burning Characteristics of Building Materials.”
- Acceptable for use in duct/plenum applications meeting the requirements of NFPA 90A
- MADE IN USA

SPECIFICATION COMPLIANCE

- ASTM C 534 Type 2 (Sheet), Grade 1
ASTM D 1056-00-2C1
New York City MEA 186-86-M Vol. IV
USDA Requirements
STC = 17 per ASTM E 90
- UL 94-5V Flammability Classification
(Recognition No. E300774)
ASTM E 84 1 1/2" 25/50-tested according to UL 723 and NFPA 255
Complies with requirements of CAN/ULC S102-03
- NFPA No. 101 Class A Rating
Meets requirements of NFPA 90A/B Sect. 2.3.3 for Supplementary Materials for Air Distribution Systems
- Meets requirements of UL 181 sections 11.0 and 16.0 (Mold Growth/Air Erosion)
- Meets requirements of ASTM C 411 (Test Method for Hot Surface Performance of High Temperature Thermal Insulation) MIL-P-15280, Form S (Sheet)
- R8 Sheet meets R-value requirements of the International Energy Conservation Code for Outdoor Ductwork.

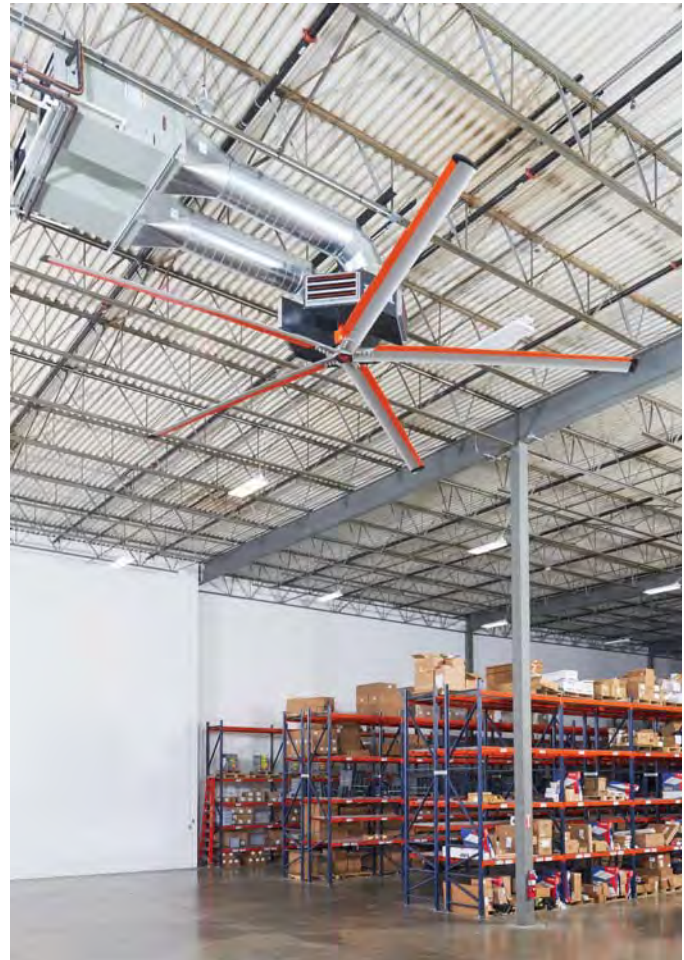

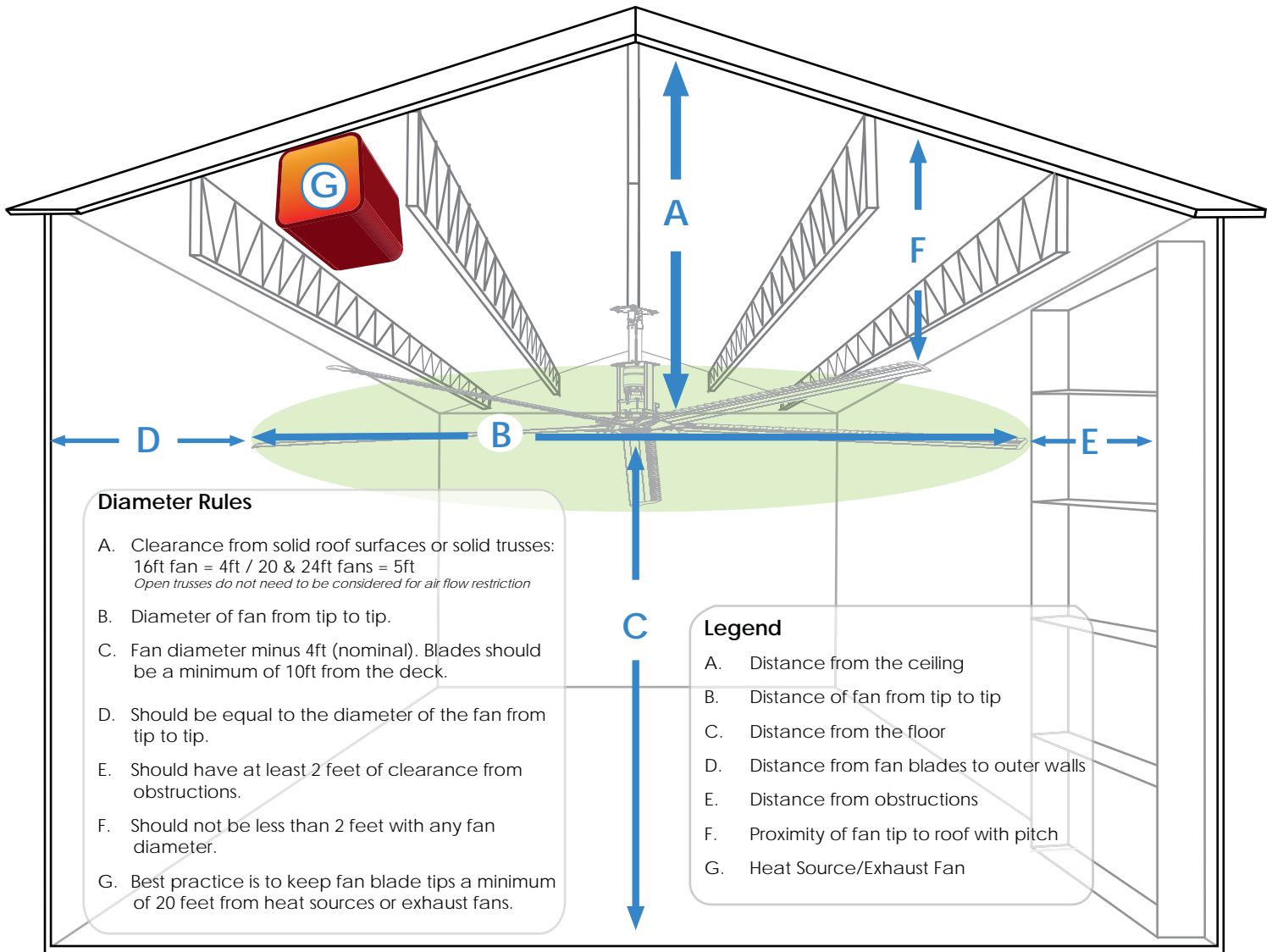

HOW TO SIZE A Z-CHILL™ FAN & DIFFUSER SYSTEM FOR YOUR FACILITY

Fan Diameter	Coverage Area (Cooling)	Coverage Area (Destratification)	Spacing Between Fans	Minimum Spacing From Wall	Clearance Needed From Ceiling	Minimum Blade Height
16 FOOT	130 FT	160 FT	120 FT	16 FT	5 FT	16 FT
18 FOOT	135 FT	180 FT	125 FT	18 FT	6 FT	18 FT
20 FOOT	150 FT	200 FT	140 FT	20 FT	6 FT	20 FT
22 FOOT	165 FT	220 FT	155 FT	22 FT	6 FT	22 FT
24 FOOT	180 FT	240 FT	170 FT	24 FT	6 FT	24 FT

24' Diameter Fan

Number of Blades: 5 patent-pending Z-Tech™ blades
 Blade Pitch: 20° plus
 Minimum Blade Height: 24 FT (blade from floor)
 Maximum Cooling Diameter: 180 FT
 Maximum Destratification Coverage: 240 FT
 Air Movement: 425,000 CFM
 Blade Rotations per minute: 53 RPM
 Nominal Motor: 2 HP (1.5kw)
 Power Consumption: 1449 watts @ 480v
 Actual Amps¹: 3.15 amps @ 480v
 Torque: 377 ft-lbs
 System Weight: 545 lbs
 Typical mounting distance between fans: 170 FT
 Clearance from solid roof surfaces: 6 FT

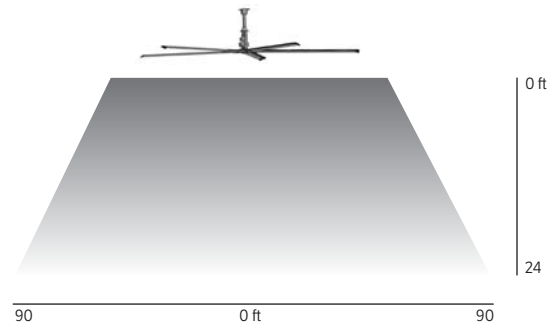

22' Diameter Fan

Number of Blades: 5 patent-pending Z-Tech™ blades
 Blade Pitch: 20° plus
 Minimum Blade Height: 22 FT (blade from floor)
 Maximum Cooling Diameter: 165 FT
 Maximum Destratification Coverage: 220 FT
 Air Movement: 385,775 CFM
 Blade Rotations per minute: 53 RPM
 Nominal Motor: 2 HP (1.5kw)
 Power Consumption: 1449 watts @ 480v
 Actual Amps¹: 3.15 amps @ 480v
 Torque: 377 ft-lbs
 System Weight: 535 lbs
 Typical mounting distance between fans: 155 FT
 Clearance from solid roof surfaces: 6 FT

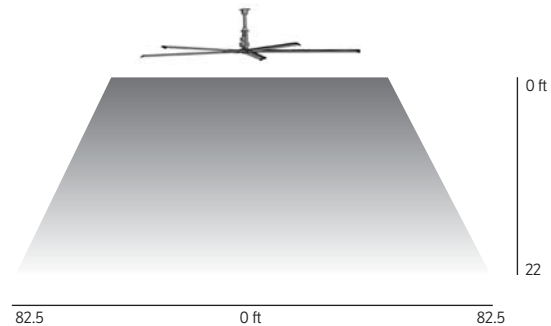

20' Diameter Fan

Number of Blades: 5 patent-pending Z-Tech™ blades
 Blade Pitch: 20° plus
 Minimum Blade Height: 20 FT (blade from floor)
 Maximum Cooling Diameter: 150 FT
 Maximum Destratification Coverage: 200 FT
 Air Movement: 346,550 CFM
 Blade Rotations per minute: 53 RPM
 Nominal Motor: 2.0 HP (1.5kw)
 Power Consumption: 1449 watts @ 480v
 Actual Amps¹: 3.15 amps @ 480v
 Torque: 377 ft-lbs
 System Weight: 525 lbs
 Typical mounting distance between fans: 140 FT
 Clearance from solid roof surfaces: 6 FT

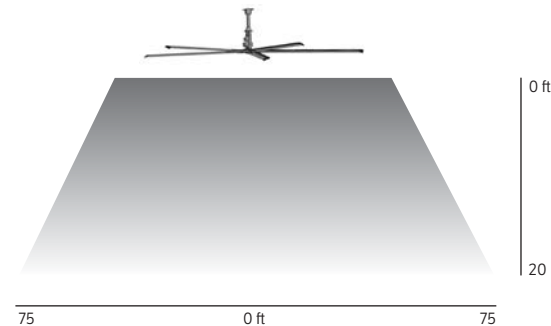

ADDITIONAL SPECIFICATIONS

- Maintain a minimum 2ft clearance from tip of blade from obstructions
- Maintain a minimum 2ft below truss with any fan diameter
- Location of fan should maintain a minimum of 20ft away from a heat source
- Location of fan should maintain a minimum of 20ft away from any exhaust fans
- Location of fan should be centered between sprinkler heads but maintain 2ft clearance from tip of blade
- Lights to be spaced 2ft or greater away from the tip of the fan blade to prevent shadowing and strobe effect

FOOTNOTE:

1.) Actual amps may vary depending on building power

18' Diameter Fan

Number of Blades: 5 patent-pending Z-Tech™
 Blade Pitch: blades 20° plus
 Minimum Blade Height: 18 FT (blade from floor)
 Maximum Cooling Diameter: 135 FT
 Maximum Destratification Coverage: 180 FT
 Air Movement: 268,920 CFM
 Blade Rotations per minute: 53 RPM
 Nominal Motor: 2 HP (1.5kw)
 Power Consumption: 1449 watts @ 480v
 Actual Amps¹: 3.15 amps @ 480v
 Torque: 377 ft-lbs
 System Weight: 505 lbs
 Typical mounting distance between fans: 125 FT
 Clearance from solid roof surfaces: 6 FT

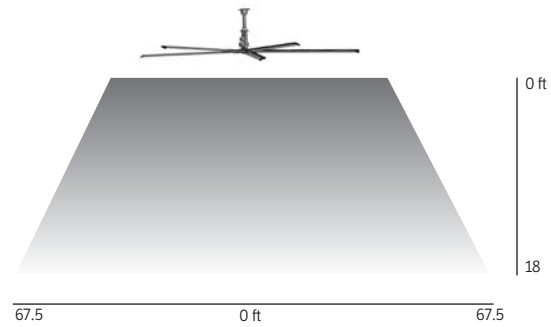

16' Diameter Fan

Number of Blades: 5 patent-pending Z-Tech™
 Blade Pitch: blades 20° plus
 Minimum Blade Height: 16 FT (blade from floor)
 Maximum Cooling Diameter: 130 FT
 Maximum Destratification Coverage: 160 FT
 Air Movement: 191,285 CFM
 Blade Rotations per minute: 70 RPM
 Nominal Motor: 1.5 HP (1.1kw)
 Power Consumption: 989 watts @ 480v
 Actual Amps¹: 2.15 amps @ 480v
 Torque: 240 ft-lbs
 System Weight: 460 lbs
 Typical mounting distance between fans: 120 FT
 Clearance from solid roof surfaces: 5 FT

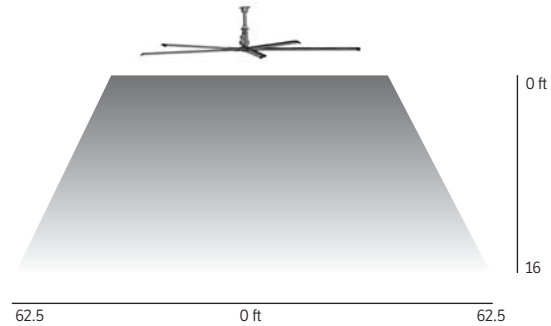

ADDITIONAL SPECIFICATIONS

- Maintain a minimum 2ft clearance from tip of blade from obstructions
- Maintain a minimum 2ft below truss with any fan diameter
- Location of fan should maintain a minimum of 20ft away from a heat source
- Location of fan should maintain a minimum of 20ft away from any exhaust fans
- Location of fan should be centered between sprinkler heads but maintain 2ft clearance from tip of blade
- Lights to be spaced 2ft or greater away from the tip of the fan blade to prevent shadowing and strobe effect

FOOTNOTE:

1.) Actual amps may vary depending on building power

Top Chord Angle Mount

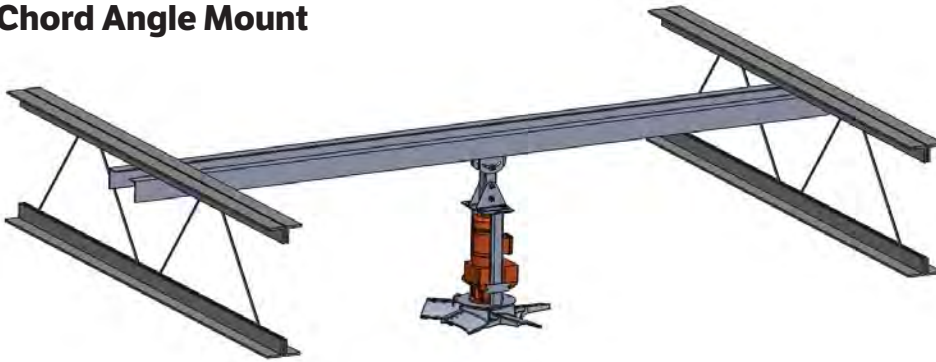

- If the installation is in a seismic zone, contact a local structural engineer to verify fan mount requirements.
- A longer down tube will be necessary to give Z-Chill™ the required clearance for the duct work. The down tube dimension should be calculated as follows: Truss height + 2 FT
- The 3" x 3" x 1/4" steel angles must be supplied by the installing contractor. Hardware used to secure the angles to the mounting structure is not included
- If the truss span is wider than 8FT, four steel angles are required. Reference the **Installation & Technical Operations Guide** or contact Go Fan Yourself® for additional instructions

Bottom Chord Angle Mount

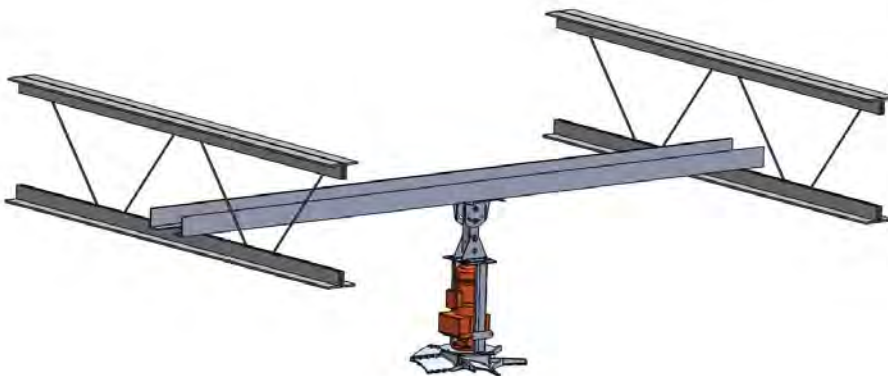

- The 3" x 3" x 1/4" steel angles must be supplied by the installing contractor. Hardware used to secure the angles to the mounting structure is not included
- If the truss span is wider than 8FT, four steel angles are required. Reference the **Installation & Technical Operations Guide** or contact Go Fan Yourself® for additional instructions
- If the installation is in a seismic zone, contact a local structural engineer to verify fan mount requirements.

Z-Purlin Mount

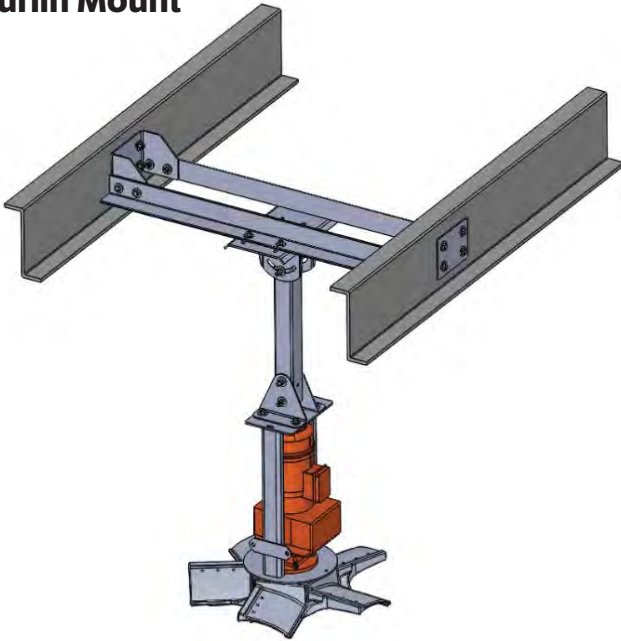

Z-Purlin Requirements

- The 3" x 3" x 1/4" steel angles must be supplied by the installing contractor
- Contact a local structural engineer for all Z-Purlin applications
- This mounting system may also be required to span concrete beams. Consult a local structural engineer for any concrete beam applications
- If the installation is in a seismic zone, contact a local structural engineer to verify fan mount requirements.

Wood Beam Mount

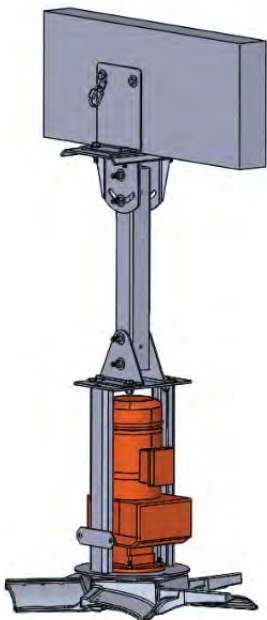

Wood Beam Requirements

- Contact a local structural engineer for all beam mount projects. The beam will need to be calculated and the method of anchoring the brackets to the beam must be verified.
- Installing contractor must supply L-bracket anchor hardware as described below:
 - (2) 1/2" - 13 x 1 1/2" longer than the support structure Grade 8 Hex Cap Screw
 - (4) 1/2" ASTM F436 Type 1 Grade 8 Mechanical Galvanized Steel Structural Flat Washer
 - (2) 1/2" - 13 Grade 8 Steel Nylock Nut
- If the installation is in a seismic zone, contact a local structural engineer to verify fan mount requirements.

Go Fan Yourself Helical Gearmotor Specifications

	2HP	1.5HP
Motor Speed (RPM)	1,660	1,660
Ratio	31.16	23.74
Output Speed (RPM)	53	70
Service Factor	1.90	2.10
Nominal Output Torque (lb -in)	2,366	1,352
Maximum Torque Capacity (lb -in)	4,532	2,885
Voltage – Single Phase (V)	200-240	100-120
Voltage – Three Phase (V)	200-240 380-480 500-600	200-240 380-480 500-600
Frequency (Hz)	60	60
Motor Enclosure Type	IP 55	IP 55
Insulation Class	F	F
Rated Current 1 (200 -240 VAC)	6.34	4.84
Rated Current 2 (380 -480 VAC)	3.17	2.42
Environmental Temp	50° C	50° C
Breather	Autovent	Autovent
Shaft Seal	Dual Output	Dual Output



NORD™ motors are quality assured based on ISO 9000 standards and designed and manufactured up to AGMA Class 13 with case-hardened steel and exceptional hardness of 60 Rc. IP 55 and UL 1004 listed; 120/230/460v; single and three phase.

The Helical In-Line gearbox from NORD™ utilizes UNICASE cast iron housing with a precise shaft and gear alignment that has a high load bearing capacity with a long operating life. NORD™ gearboxes are complimented frequently on quiet running operation.

The Unicase housing from NORD™ is a single housing block in which all bearing points are integrated. In this way, no sealing faces are subjected to torque or lateral forces caused by flanges or bearing points that are screwed on. All axes and sealing faces of the gear block are machined in a single setup on the most modern CNC-controlled production lines, which translates to the highest degree of manufacturing accuracy.

NORD™ utilizes heavy duty (VL) bearings over standard bearings so the bearing sizes are larger and offer high load capacity. The thick wall housings provide stable shaft and bearing centers which promotes higher bearing and gearing life. The housing features a high quality paint system. The housing is primed, then a Polyurethane coating is applied and each unit is hand sprayed to cover all surfaces and inspected to high standards.

Protective features to eliminate damage include Autovent and Quadralip.

- Autovent helps prevent bearing and gear damage by utilizing cleaner gearbox oil with an extended lubrication life and longer lasting seals, gears and bearings. The Autovent system is not open to the atmosphere, yet allows the internal of the unit to release pressure, if needed, in extreme thermal conditions. The ball-check valve is spring loaded to release at 2-3 PSI.
- The Quadralip sealing provides superior protection against leaks and contaminants. Two-component paint resin withstands exposure to acids, alkalis, solvents and oil based product with enhanced chemical resistant and USDA approved standard paint.

ABB ACS255 VFD Controller

100-120V 1 Phase
 200-240V 1 Phase



ABB ASC355 VFD Controller

200-240V 3 Phase
 380-480V 3 Phase
 500-600V 3 Phase



ASC355 Fan Control

- ABB™ Variable Frequency Drive Enclosure - solid aluminum powder coated frame with a plastic IP67 cover and membrane covered touchscreen.
- Advanced multi function keypad with a display keypad that allows for quick on demand program changes
- NEMA 4X, IP66, ROHS compliant; 50/60 HZ operation
- Run up to 26 fans from a single keypad (additional wiring required)
- Deepest heat sink in the industry extends the life of drive and controller
- Install up to 200 feet from fan; disconnect per NECA code within eyesight
- 5 digital inputs, all programmable. 1 digital NO/NC and 1 Relay (AC/DC)
- 0(4) - 20mA analog output. This allows the speed reference control from drive to drive without the need to use resistors on the circuit.
- Ethernet compatible
- Highly customizable programming
- Capable of linking to building automation systems
- Controls ship standard with an Early Suppression Fast Response relay ready to connect to existing fire suppression systems and an integral lock out, tag out disconnect

ASC250 Fan Control

- 100-120VAC | 200-240VAC single phase (Single Phase Available For 16FT Fan Size Only)
- Cannot be utilized to control multiple fans with a single controller

Custom Programming

There will be a minimum charge placed on any order (this is a per order charge, not per fan) when custom programming is involved. Lead time will be increased.

Custom Programming includes:
 Controlling multiple fans from a single keypad
 Connecting to building management systems or other software/hardware packages
 Any customer requests beyond the standard one drive controls one fan

The remote keypad option is not considered custom programming.



- Optional Remote Keypad provides unlimited flexibility for your Go Fan Yourself® fan installation
- Mount the VFD controller in the ceiling or high on the column for safety and security and drop the keypad down to a user friendly mounting height
- Remote keypad option ships from Go Fan Yourself® with a 25FT CAT6 data cable allowing the keypad to be mounted approximately 25 feet below the VFD controller
- Maximum CAT6 data cable length is 300FT



GFY® Standard RAL Colors

- Black #9005
- Orange #2004
- Green #6024
- Yellow #1018
- White #9003
- Red #3002
- Blue #5005
- Blue #5015
- Silver #9007C

Option #1
Motor, Z-Tech™ & Logo



Option #2
Motor, Mixed Z-Tech™ & Logo



Option #3
Motor, Z-Tech™,
Aluminum Blades & Logo



Option #4
Motor, Mixed Z-Tech™,
Aluminum Blades & Logo



Custom RAL*
Motor, Z-Tech™,
Aluminum Blades & Logo



- Motors are only available in GFY® standard RAL colors
- Fill out the order form on the following page and submit the completed Designer Color Order Form with your fan order
- Submit customer artwork for the logo in an Adobe Illustrator file electronically to Go Fan Yourself® when placing the order
- All custom color requests must be approved by Go Fan Yourself® as additional cost and longer lead times may apply
- Only the components listed have optional colors
- All custom colors may not be available or may not be available on all components.
- Consult RAL website for color definitions (www.ralcolors.com)

Instructions:

- 1) This form must accompany the GFY® Z-Tech™ fan order
- 2) Complete one form for each unique Designer Series Color fan
- 3) Reference the Go Fan Yourself® standard RAL color list (shown to the right)
- 4) Enter the RAL number for each fan component
- 5) Logo must be sent to Go Fan Yourself® with fan order in an Adobe Illustrator file
 - a) All custom colors must be quoted for both cost and lead-time.

GFY® Standard RAL Colors

- Black #9005
- Orange #2004
- Green #6024
- Yellow #1018
- White #9003
- Red #3002
- Blue #5005
- Blue #5015
- Silver #9007C

Motor Color

Enter standard RAL number from the list above.
Motors are only available in standard 8 RAL colors.

Z-Tech™ Color

Color #1 (all 5 or 3 of 5 blades)

Color #2 (2 of 5 blades)

Custom colors available.
Contact Go Fan Yourself™ for cost and lead time.

Blade Color

Enter blade color.
All 5 blades must be the same RAL color.
Contact Go Fan Yourself™ for cost and lead time.

Custom Logo

Logo must be sent in an Adobe Illustrator file.

Notes